

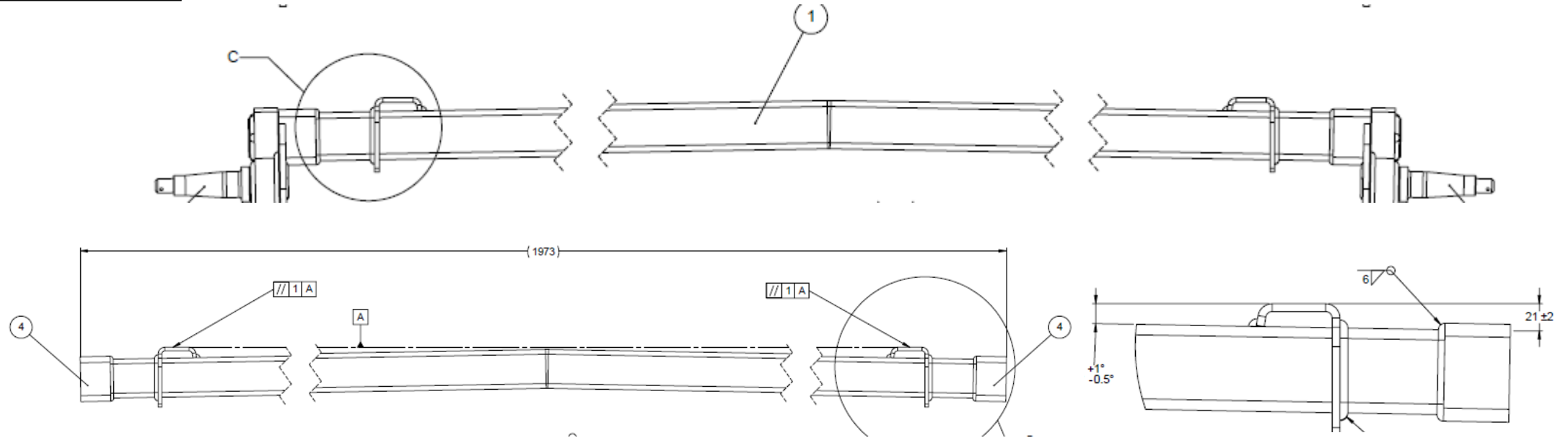

Positive Camber Bend on Trojan Duratorque Axles



Trojan Duratorque trailer axles are designed with a “bend” in the tube that will deflect when the load (weight of the trailer) is applied. This will bring the trailer wheel camber toward a 0 value that is the best setting for most trailer applications. This will allow the tyres to wear evenly and allow the longest tread life.